

LED warning beacon / LED warning flashlight 230V AC, type: RWL 11

 technical data:

item number.:	S0006813
part description:	LED warning beacon, type RWL11
housing:	top / cap: Makrolon (PC), bottom: ABS
color:	RAL 2000 / orange
dimensions (d x h):	175 mm x 146 mm (h x d)
weight:	500 g
protection:	IP65
lighting power:	84 bright shining LED with approximately 5000 mCd, a 360 degree light radiation
light effect / repetition frequency:	rotary beacon , approx.. 2 Hz
expected lifetime of LED *: <small>*) as specified by the LED-manufacturer</small>	> 7 x 10 ⁷ flashlight pulses*
mounting and installation:	3-point –mounting from bottom, upright , according to instruction leaflet
mounting and cable entry:	9 mm hole, with rubber grommet 6 mm whole cable entry from the bottom
cable connector block:	connector for all wires up to 4mm ² ,removable
power supply:	230 V AC
load:	ca. 2 Watt
typ. current consumption:	50 mA
temperature:	-20° bis + 70°C
marking:	



RWL 11, signal color orange

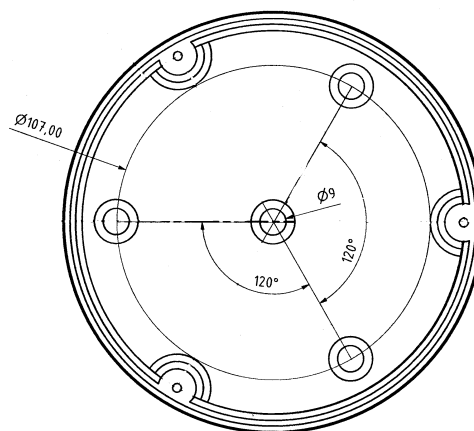

cable entry and mounting holes